

**Mounting Flange Details**

Common to All RISTEC-071 Sized Modules

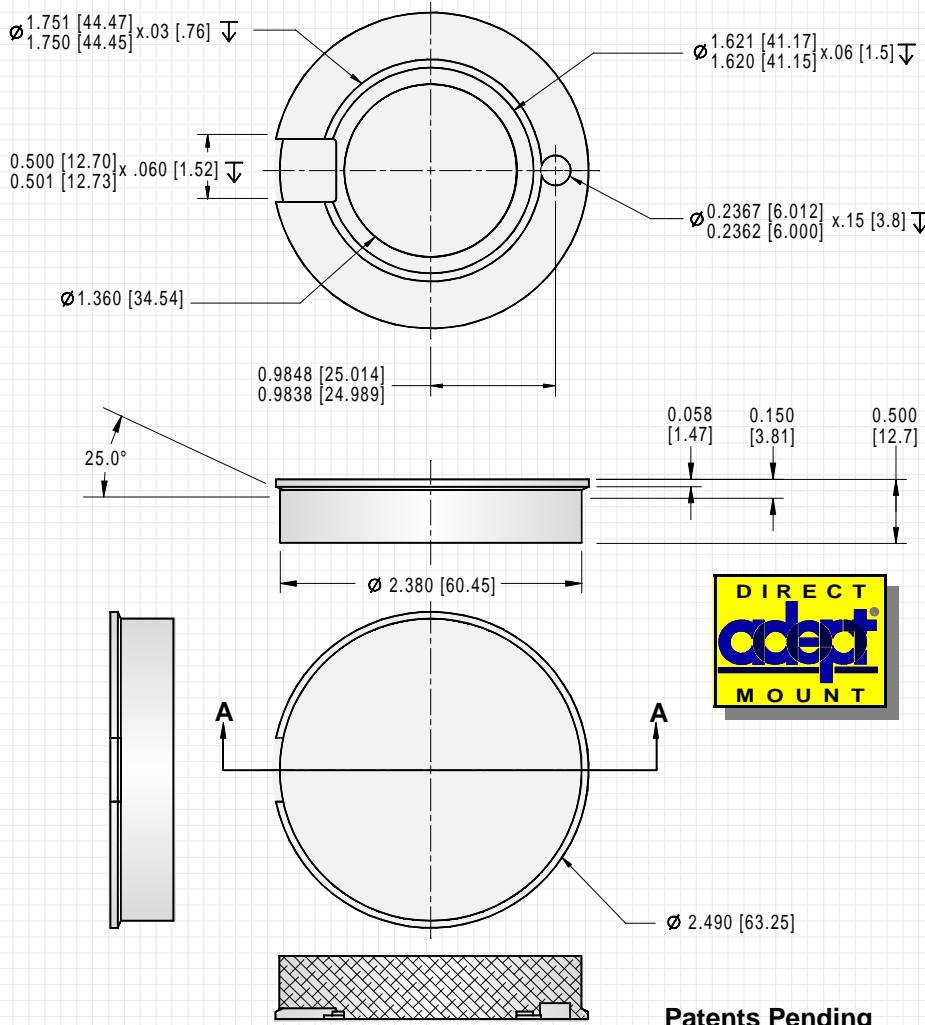

Patents Pending

**ORDERING**

Order Accessories & Modules Separately

**ORDER NUMBER:** M AP - 071 - 002

**Product Family:**

Mounting Accessories **M**

**Accessory:**

Adapter Plate **AP**

**Size:**

For All -071 mm OD Modules **071**

**Style:**

Thick section **002**

**Mass Properties:**

Weight [Mass]	<b>W</b>	0.22 Lb	0.10 Kg
Center of Gravity	<b>Cg</b>	0.25 in	6.3 mm

[Download .PDF](#)

[MAP-071-002-PDF.zip](#)

[This Data Sheet](#)

**2D & 3D CAD Files**

[MM-071-2D-DWG.zip](#)

[MM-071-2D-DXF.zip](#)

[MM-071-3D-DWG.zip](#)

[MM-071-3D-ACIS.zip](#)

[MM-071-3D-STEP.zip](#)

[CAD File Downloads](#)

**ACCESSORIES:** order separately

Clamp Collar Kit for Tool Holder **MCC-071-002**

Clamp Collar Kit **MCC-071-001**

Blank Adapter Plate, Thin **MAP-071-001**

